

SlimStile BA Lite

Tripod Turnstile for Internal Installation

Drive

Hand-operated, bidirectional

Materials

Casework: Galvanised painted steel 430

Casework lid: Stainless Steel AISI 304 (1.4301 as for EN10088-1)

Tripod hub: Cast aluminium with painted grey finish

Tripod arms: 38mm dia. 480mm 304 Stainless Steel AISI 304 (1.4301 as for EN10088-1), with welded end caps

Mechanism

Electro-mechanical head mechanism :

- Positive locking action for one passage at a time
- Self-centering mechanism to ensure complete rotation into the home position
- Anti-backup device to prevent reverse rotation once the mechanism has moved from 60° from home

Power Failure / Fire Alarm

- Either one or both directions can be fail-safe (standard), i.e. rotates freely, or fail lock, i.e. locks in the home position
- Fire alarm - emergency input. Input facility available for free voltage contact to effect fail-state
- Mechanism fail state will be the same as power failure choice
- Drop arm option: the horizontal arm drops to create passage for evacuation
- Static hub option: free rotation

Interface

- LL2001Lite microprocessor control logic:
- One input for opening/locking in each direction
- Two protected outputs controlling opening/locking
- Four protected outputs piloting way mode indicators
- Two protected outputs counting passage in either direction
- Two OV output relays indicating availability of use or counting passage in either direction
- Two open collector NPN outputs to count passage or to indicate availability of use in either direction or activate the optional drop arm
- Features a Serial Port - RS485



PRODUCT DESCRIPTION

Tripod Turnstiles are compact and cost-effective solutions, suitable for areas where there is a large flow of people. Ease of use, reliability and robustness are key features in this product.

APPLICATIONS

- Government
- Retail
- Finance
- Telecommunications
- Banking
- Publishing
- Leisure and Entertainment
- Petrochemical
- Education
- Public Toilets.....



Smart Intrusion Solutions

www.smartintrusions.com

SlimStile BA Lite

TECHNICAL DATA

Dimensions	See detail on next page
Power Supply	230Vac 50 Hz or 115Vac 60 Hz
Power Rating	50VA (stand by 5VA if Normally Open)
Operating Temperature	0 to +45 °C (RH 95% not condensing)
IP rating / MCBF / MTTR	IP 20 / 1.5M cycles / less than 30 min
Flow Rates (approx)	Proximity Reader "Hands Free", 40 passages per minute

MODELS AVAILABLE

- SlimStile BA Lite Drop Arm
- SlimStile BA Lite Static Arm

OPTIONS

- Surface mounted card reader drilling
- Waymode Indicator
- Electro-mechanical counter

SlimStile BA Lite

SITE PREPARATION

Product delivered fully assembled and may require lifting equipment
Approx. weight: 40Kg
(For installation details, please refer to the installation manual.)

Pedestal Mounted

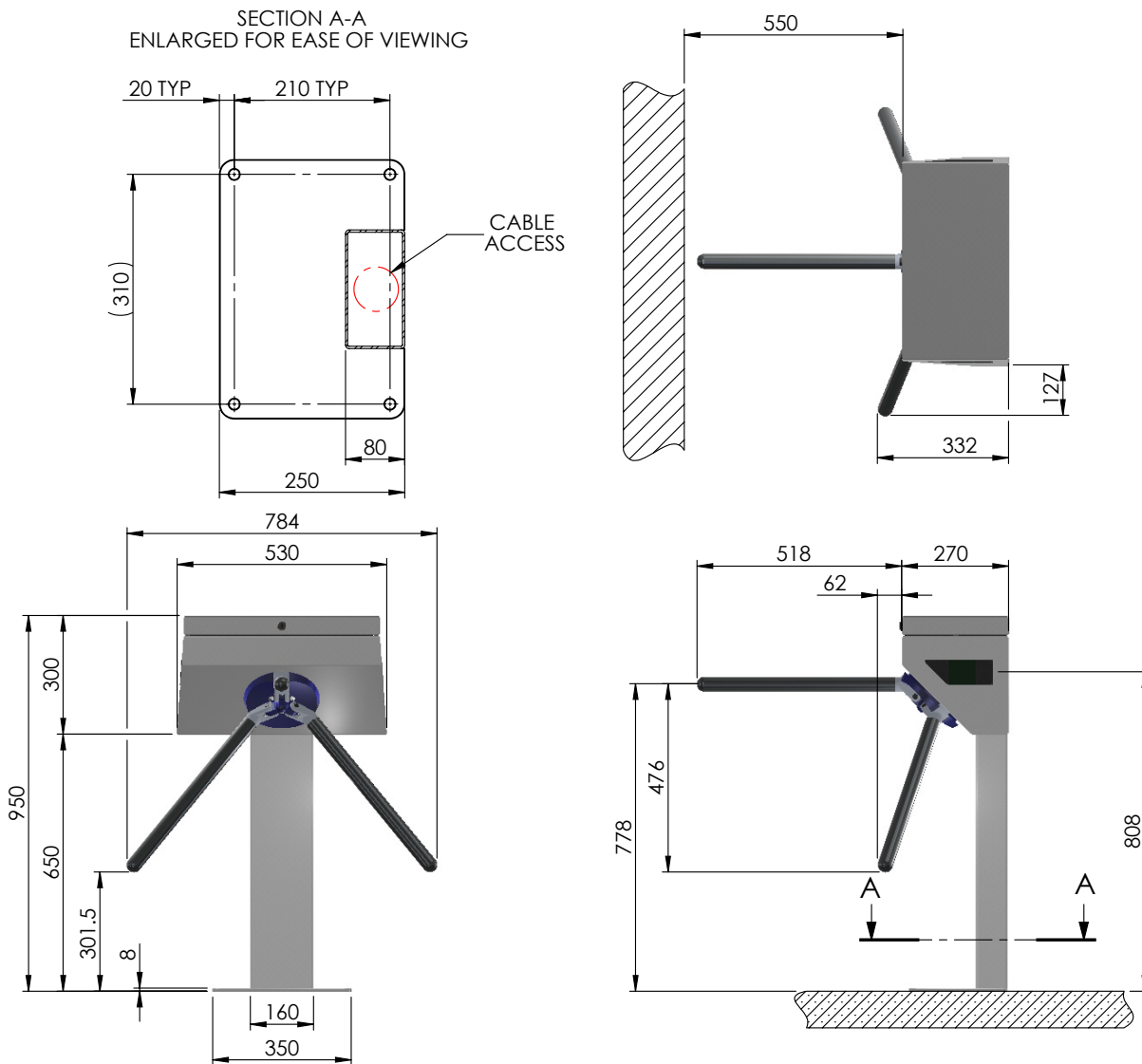

Concrete Base to specification at least fck (cube) 300N/mm² of resistance.
Base to be flat and level to +/- 5mm over footprint area. Dimensions to be
> 700 x 500 x 150 deep min

SlimStile BA Lite

IMPORTANT

- Any horizontal pipe or conduit running below the Tripod Turnstile must be at least 140mm below FFL
- Metal conduit for cables should be raised at least 50mm from foundation
- It is the customer's responsibility to ensure the structural integrity and strength of the installation location
- The dimensions given in this Product Data Sheet are for information only. In order to prepare the installation site, please refer to the installation manual or contact your usual Gunnebo Customer Service

For further information, please contact:

Gunnebo Entrance Control Ltd

Tel: +44 1825 761 022

Fax: +44 1825 763 835

Email: info.entrancecontrol@gunnebo.com

Note: In pursuit of its policy of continuous refinement and improvement, Business Area Entrance Control reserves the right to modify design and details at any time and without notice.



www.smartintrusions.com

GUNNEBO[®]
For a safer world