



## PasSec

### Anti-Return Gates

The Gunnebo PasSec is a solution for preventing travellers returning back into secure or sensitive environments.

Located ideally after Immigration control but before baggage reclaim to prevent passengers collecting luggage and inadvertently attempting to return back to airside, or after customs but before the open landside area to prevent unauthorised access to the baggage claim and any secondary exit duty free areas by the general public.

The PasSec is available in three different standard models offering a single door, double door with custom corridor and a high security version offering many additional security features.

Utilising different detection technologies, the anti-return solution monitors the free passage travel in one direction tracking the occupants through the monitored corridor until they exit. As soon as any wrong way passage is detected this will be identified and the system will automatically close and lock the doors plus generate an alarm both locally and remotely to notify security or CCTV surveillance.

Passage is free and simple, as there is no need for the passenger to present any clearance documentation for the doors to open.

Control is also simple either locally should security need to be in attendance, or remotely to minimise staffing levels.



Smart Intrusion Solutions

# PasSec

## Technical Specifications

### Drive

High reliability DC motor with 5 speed settings

### Materials

Casework: Mild steel and aluminium painted RAL9006  
Moving panels: 12mm frameless and structural toughened glass  
Side panels: 10mm toughened glass infill

### Operating Modes

Entry - free

By key selector, the PasSec can be operated in four modes

- Automatic: Unidirectional in the exit direction only
- Interlocking: Unidirectional controlled passage (HSW)
- Maintenance: No control in either direction
- Locked: Walkway closed and locked

By means of remote inputs, it is possible to select automatic, interlocked and locked modes, as well as operate both entry and exit doors.

### Passage Sensors

Different sensors analyse the movement of passengers, detect the direction, position of travel and activate the doors accordingly. Should passage in the reverse direction be detected, the sensors will instruct the doors to close and trigger an alarm. Sensors detect left luggage.

### Controlling Unit

Gunnebo NEP controller 24Vdc

### User Interface

- 7 relays with different sets of status flags
- 8 inputs, to control by remote the operating mode: RS485, RS232 (only for debug)
- Local and remote diagnostic alarm display facilities
- Adjustable parameter control via User Interface, i.e. speed timeouts, etc.

### Alarm Conditions

Alarm triggered in case of door obstruction, wrong way usage, and system diagnostic failure.

### MODELS

- Single (S)
- Double (D)
- High Security Double (HS)

### BENEFITS

- Reduction in staffing costs
- Superior anti-return detection
- Left luggage detection (HSW)
- Unobtrusive design combined with highly glazed aesthetic
- High visibility of traveller progress

### FEATURES

- 650 and 950mm clear walkways to comply with disability legislation
- Free passage, in transit anti-return, wrong way detection and left item detection (depending upon model chosen)
- Interlock function (HSW only)
- Stainless steel and other finishes options
- Fail lock or fail safe configuration (factory set up)
- Local and remote control override
- Traveller status light indicators

### APPLICATIONS

- Airport
- Seaports
- Museums

### TECHNICAL DATA

- Power Supply 115/230Vac 50/60Hz
- Power Rating 600VA peak/100VA standby
- Operating temperature 5°C to 45°C 95% RH non-condensing
- Flow Rates 50 to 100 passages per minute depending upon passenger speed of travel

# PasSec S/SW



## Single door and anti-return detection

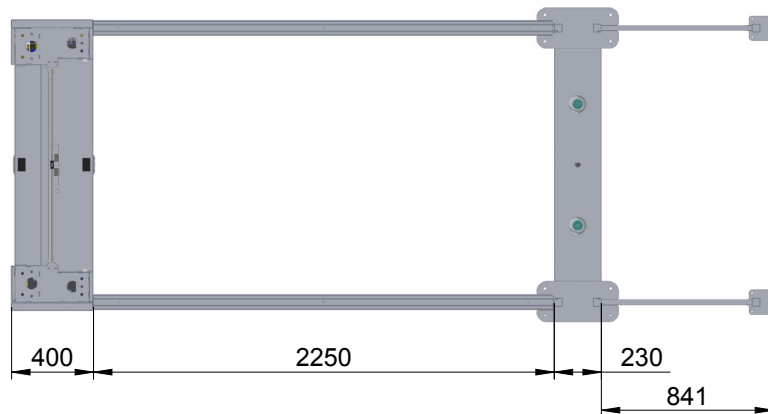
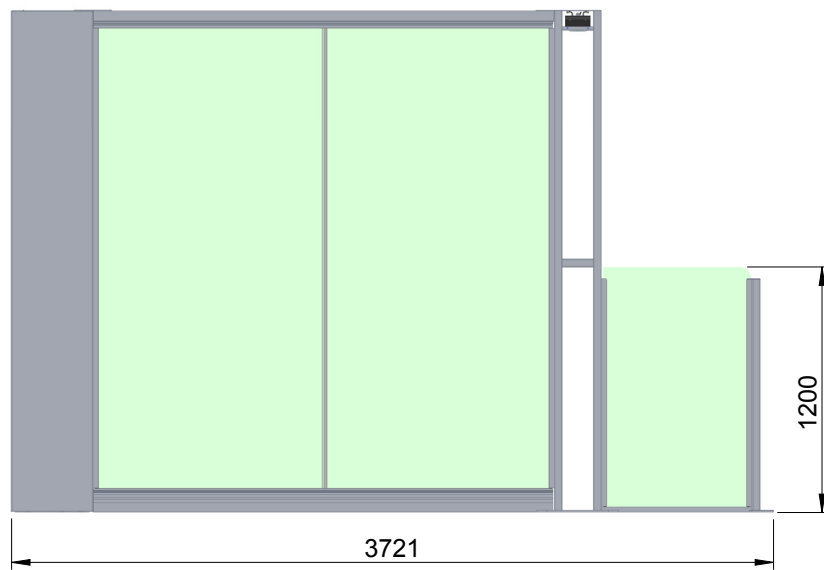
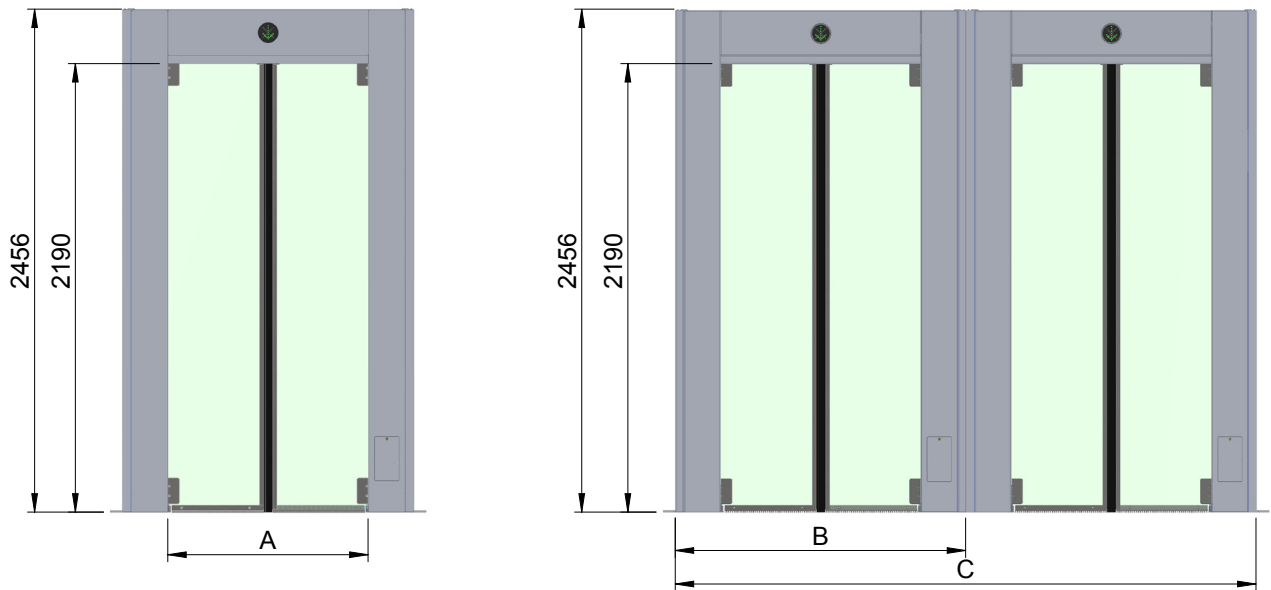

Concrete Base to specification at least (cube) 300N/mm<sup>2</sup> of resistance. Base to be flat and level to +/- 5mm over footprint area.

A	B	C
650	1112	2224
950	1412	2824

# PasSec D/DW



Double door, anti-return detection and customisable corridor

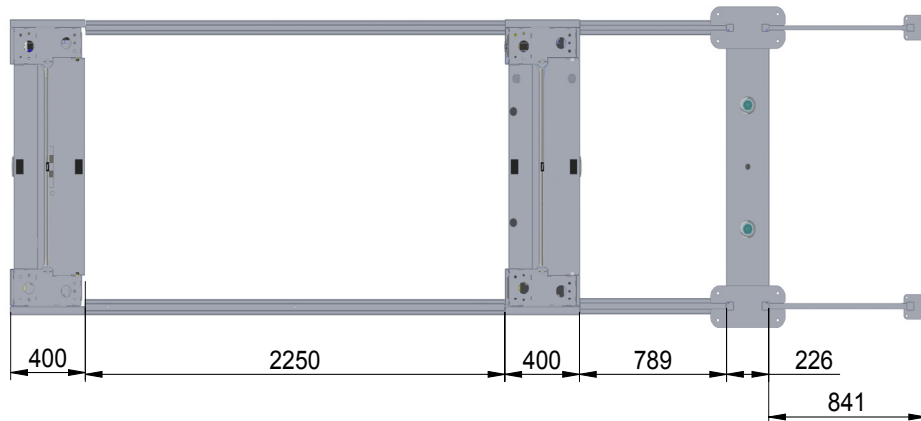
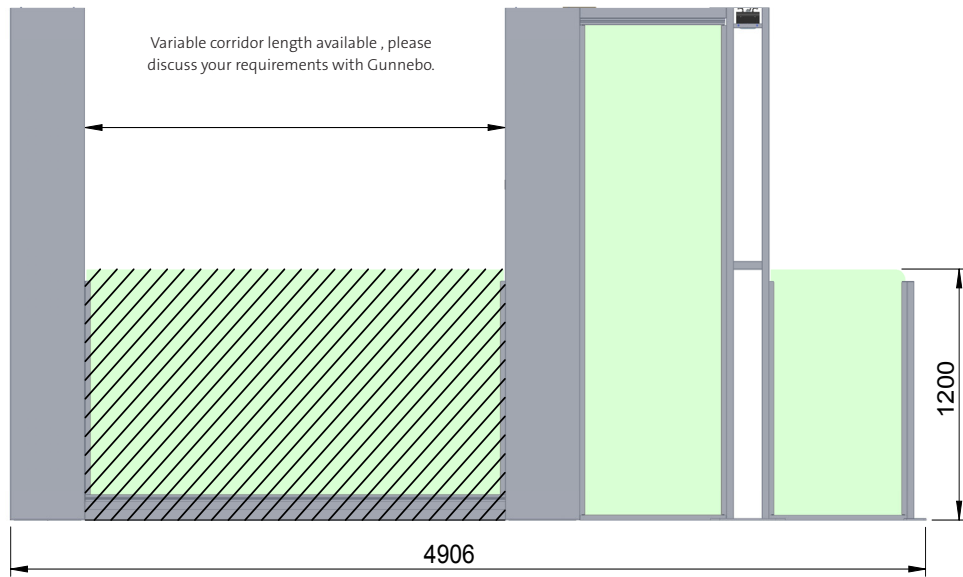
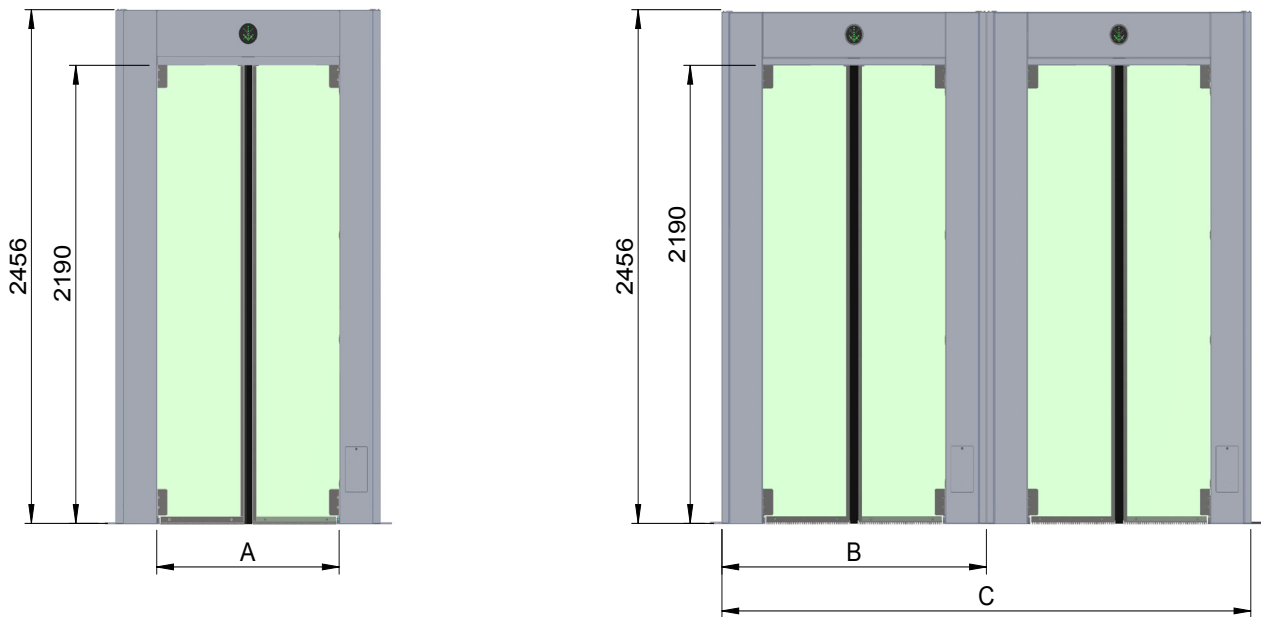

Concrete Base to specification at least (cube) 300N/mm<sup>2</sup> of resistance. Base to be flat and level to +/- 5mm over footprint area.

A	B	C
650	1112	2224
950	1412	2824

# PasSec HS/HSW



Double door, anti-return left item detection and additional interlock mode

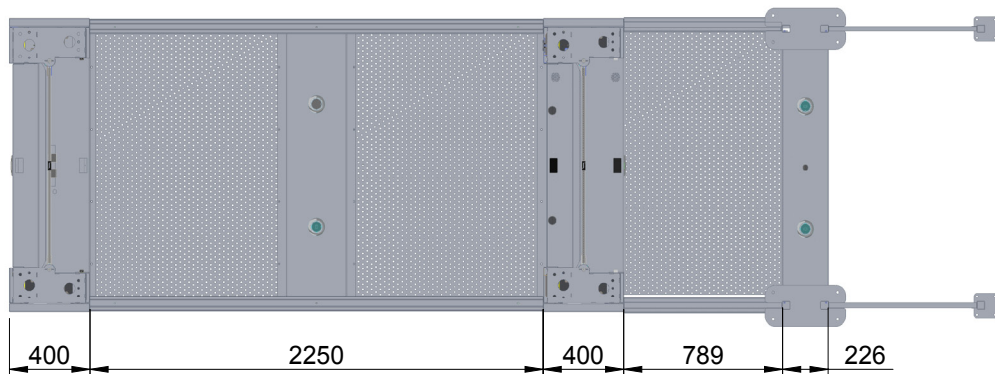
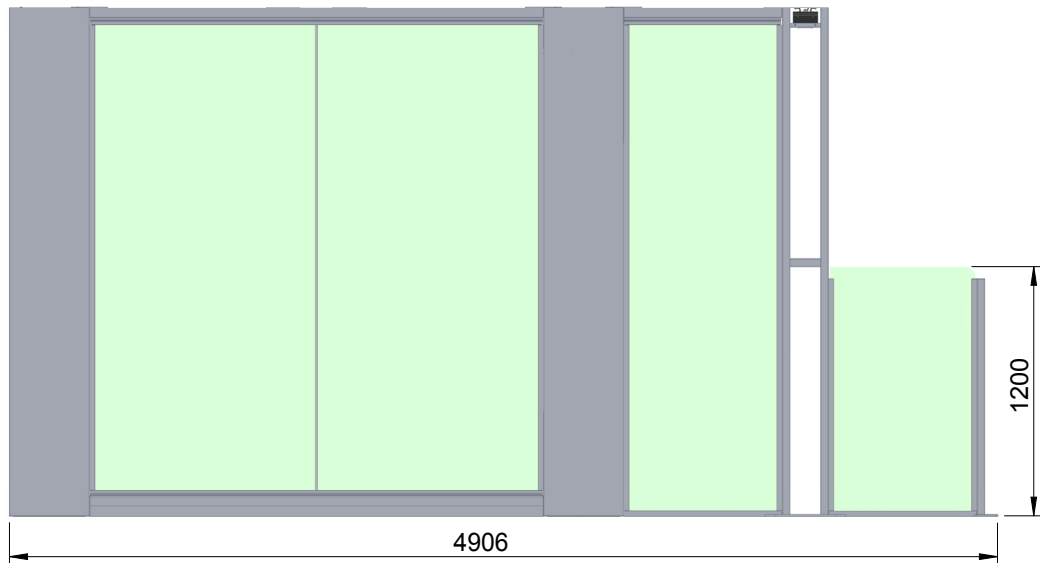
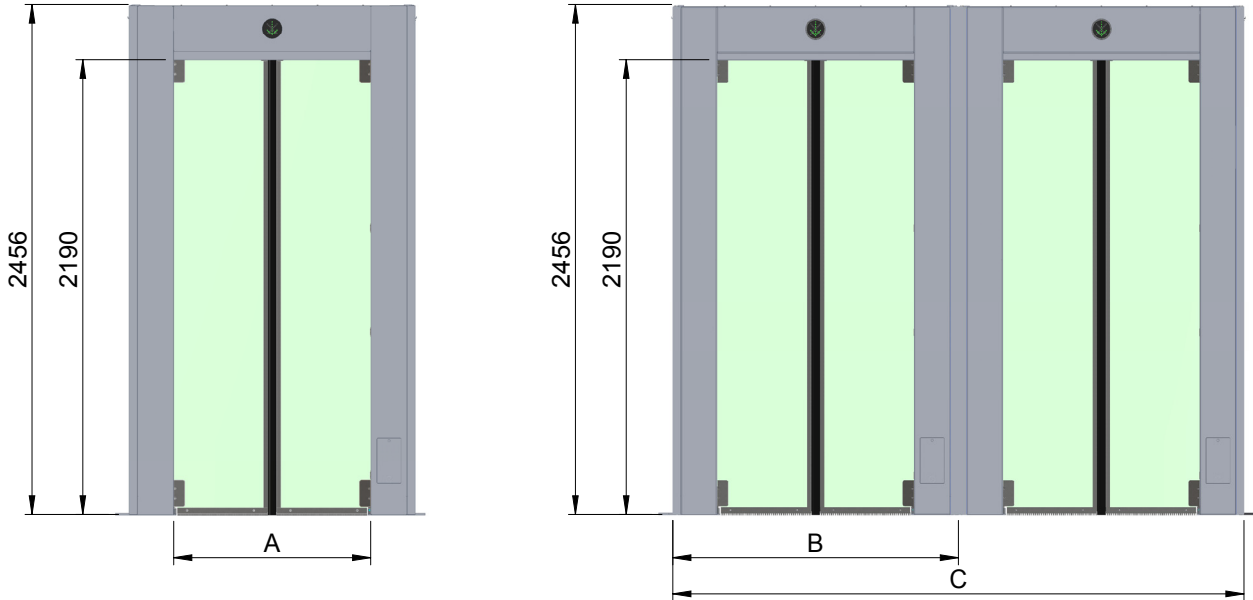

Concrete Base to specification at least (cube) 300N/mm<sup>2</sup> of resistance. Base to be flat and level to +/- 5mm over footprint area.

A	B	C
650	1112	2224
950	1412	2824

## International Standards

CE compliance meeting the following directives:

- 89/336/EC EMC
- 72/23/EC Low Voltage
- 987/37/EC Machinery

Norms

- EN 60335-1 (2002) Safety of Household appliances and special electrical appliances
- EN 61000-6-3 (2002) Electromagnet compatibility - generic standard, emission
- EN 61000-6-2 (2002) Electromagnet compatability - generic standard, immunity
- UL compliance to the standard:  
UL 325 Door, Drapery, Gate, Louver and Window Operators and Systems

For further information please contact:

Gunnebo Entrance Control  
Bellbrook Business Park  
Uckfield TN22 1QQ  
United Kingdom

Tel +44 1825 761 022  
E-mail [info.entrancecontrol@gunnebo.com](mailto:info.entrancecontrol@gunnebo.com)  
Web [www.gunnebo.com](http://www.gunnebo.com)



In pursuit of its policy of continuous refinement and improvement, Gunnebo reserves the right to modify design and details given in this material at any time and without notice. Images enclosed in this material are examples of installations and may not be indicative of a standard product.