



SafePoint Alisea

Functional cash protection solution



Smart Intrusion Solutions

www.smartintrusions.com



Functional cash protection solution

SafePoint Alisea is designed for the storage of cash in the workplace and has a programmable time-delay feature to ensure security. The unit is available in four ergonomically designed models with an easy-to-use control panel and door opening to 90°.

To optimise storage, there is an extensive range of fittings options, including a coin drawer, stationery drawer, security compartment. An optional “discretion shutter” can also be added to conceal the contents of each drawer.

Features

1. Personalised security levels
2. LED, digital time display and keyboard, time controls, display code controls
3. Networking of several Alisea units
4. Connection to the central security system
5. Motorised locking system
6. Bundle deposit



Specifications				
	15A	15C	25A	25C
Height	540	540	667	667
Width	450	450	450	450
Depth	550	550	550	550
Weight (kg)	55	55	62	62

Control Panel				
	15A	15C	25A	25C
With display	•	•	•	•
With display and keyboard	–	•	–	•

Configuration	
15A/C	25A/C
1 stationery drawer, 1 drawer, 1 container with door	1 stationery drawer, 2 drawers, 1 container with door



Lockable banknotes case available as option (supplied with 2 keys).

SafePoint Alisea can be anchored to the floor, in the same way as a safe, or mounted in the base. It can also be fitted directly into the furniture using a special fixing kit.

A single key is used for activation, deactivation and locking the drawers, and the electronic control panel is used to operate the unit. The panel also displays the number of minutes remaining on the time delay.

An electronic control interface within reach (improved ergonomics.)

Certain models available with an additional storage drawer.

An optional “security lid” protects the contents of the drawer from prying eyes.

Options

Lockable banknotes case (with 2 keys)

Security lid

Pedestal without wheels (60/80mm)

Pedestal with wheels (187mm)

Duress alarm kit

Cheque divider kit

Deposit box

Fixing kit for floor anchoring (4 screws)

Outline drawing – horizontal section

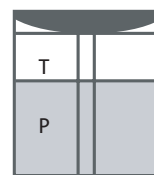
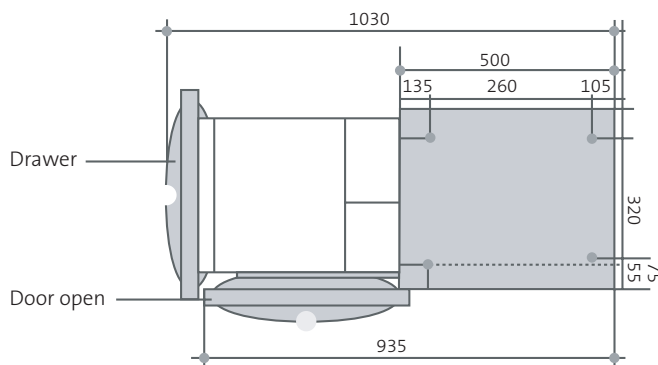

15 A/C

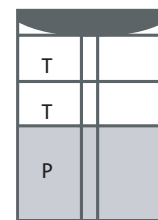

25 A/C

Gunnebo is a leading provider of efficient and innovative security solutions and services to customers around the globe. It employs 5700 people in 32 countries across Europe, Asia, Africa, Australia and the Americas, and has a turnover of €580m. Gunnebo focuses its offering on Bank Security & Cash Handling, Secure Storage, Global Services and Entrance Control.

We make your world safer.



Smart Intrusion Solutions

www.smartintrusions.com

GUNNEBO[®]
For a safer world